

PC-HELPER

Isolated Digital I/O
Terminal for USB2.0

DIO-0808LY-USB

User's Guide

CONTEC CO.,LTD.

Check Your Package

Thank you for purchasing the CONTEC product.

The product consists of the items listed below.

Check, with the following list, that your package is complete. If you discover damaged or missing items, contact your retailer.

Product Configuration List

- USB terminal [DIO-0808LY-USB]...1
- Interface connector plugs...2
- First step guide...1
- CD-ROM *1 [API-USBP(WDM)]...1
- USB Cable(1.8m)...1
- USB Cable Attachment...1

*1 The CD-ROM contains the driver software and User's Guide (this guide)

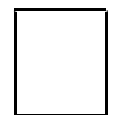
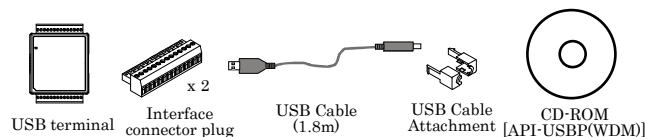

First step guide

Copyright

Copyright 2006 CONTEC CO., LTD. ALL RIGHTS RESERVED.

No part of this document may be copied or reproduced in any form by any means without prior written consent of CONTEC CO., LTD.

CONTEC CO., LTD. makes no commitment to update or keep current the information contained in this document. The information in this document is subject to change without notice.

All relevant issues have been considered in the preparation of this document. Should you notice an omission or any questionable item in this document, please feel free to notify CONTEC CO., LTD.

Regardless of the foregoing statement, CONTEC assumes no responsibility for any errors that may appear in this document or for results obtained by the user as a result of using this product.

Trademarks

MS, Microsoft, Windows and Windows NT are trademarks of Microsoft Corporation. Other brand and product names are trademarks of their respective holder.

Table of Contents

Check Your Package	i
Copyright	ii
Trademarks	ii
Table of Contents	iii

1. BEFORE USING THE PRODUCT	1
------------------------------------	----------

About the Product	1
Features	1
Support Software.....	2
Cable & Connector (Option).....	2
Accessories (Option).....	2
Customer Support.....	3
Web Site	3
Limited Three-Years Warranty.....	3
How to Obtain Service.....	3
Liability	3
Safety Precautions	4
Safety Information	4
Handling Precautions.....	4
Environment	6
Inspection	6
Storage.....	6
Disposal	6

2. SETUP	7
-----------------	----------

What is Setup?.....	7
Installing the driver	7
Step 1 Setting the Hardware	8
Name of each parts.....	8
Step 2 Initializing the Software	9
Illustration of Menu Screen	9
Installation of API-USBP(WDM) Development Environment.....	10
Step 3 Installing the Hardware	11
Connecting the Product.....	11
Setting with the Add New Hardware Wizard	12
Setting Properties Using Device Manager	13
Step 4 Checking Operations with the Diagnosis Program	15
What is the Diagnosis Program?	15
Using the Diagnosis Program	15

3.	EXTERNAL CONNECTION	19
-----------	----------------------------	-----------

Using the On-terminal Connectors	19
Connecting a terminal to a Connector	19
Connector Pin Assignment.....	20
Relationships between Logical Ports/Bits and Connector Signal Pins	21
Cable connection	21
Connecting Input Signals	22
Input Circuit.....	22
Connecting a Switch.....	22
Output Circuit	23
Output Circuit	23
Example of Connection to LED.....	24
Example of Connection to TTL Level Input	24
Connecting the Sink Type Output and Sink Output Support Input	25

4.	APPLICATION DEVELOPMENT	27
-----------	--------------------------------	-----------

Reference to Online Help	27
Printing Function Reference	27
Sample Program.....	28
Distributing Developed Application	28
Returning to Initial State	29

5.	FUNCTIONS	31
-----------	------------------	-----------

Data I/O Function	31
Data Input	31
Data Output.....	31

6.	ABOUT HARDWARE	33
-----------	-----------------------	-----------

Hardware specification.....	33
External dimensions	34
Block Diagram.....	35

1. Before Using the Product

About the Product

This product is a USB 2.0 compliant terminal that extends the digital signal I/O functions of a PC. This product is a 12 - 24VDC opto-coupler isolated type that does not require external power with input 8 channels and open-collector output 8 channels. In addition, output transistor protection circuit (surge voltage protection and overcurrent protection) are provided. Windows driver is bundled with this product.

Possible to be used as a data recording device for LabVIEW, with dedicated libraries.

Features

- Opto-coupler isolated input (supporting current sink output) and opto-coupler isolated open-collector output (current sink type)

This product has the opto-coupler isolated input 8 channels (supporting current sink output) and opto-coupler isolated open collector output (current sink type) 8 channels whose response speed is 300 μ sec .

Supporting driver voltages of 12 - 24 VDC for I/O.

- Compatible to USB1.1/USB2.0 and not necessary to power this product externally as the bus power is used.

Compatible to USB1.1/USB2.0 and capable to achieve high speed transfer at HighSpeed (480 Mbps). Not necessary to power this product externally as the bus power of USB is used.

- Opto-coupler bus isolation

As the USB (PC) is isolated from the input and output interfaces by opto-couplers, this product has excellent noise performance.

- Output circuits include zener diodes for surge voltage protection and poly-switches for overcurrent protection.

Zener diodes are connected to the output circuits to protect against surge voltages. Similarly, polyswitches are fitted to each group of 8channels outputs for over-current protection.

The output rating is max. 35VDC, 100mA per channel.

- Windows compatible driver libraries are attached.

Using the attached driver library API-USBP(WDM) makes it possible to create applications of Windows. In addition, a diagnostic program by which the operations of hardware can be checked is provided.

- Easy-to-wire terminal connector adopted

Adoption of terminal connector (with screws) enables to achieve easy wiring.

- LabVIEW is supported by a plug-in of dedicated library VI-DAQ.

Using the dedicated library VI-DAQ makes it possible to create each application for LabVIEW.

Support Software

You should use CONTEC support software according to your purpose and development environment.

Driver Library **API-USBP(WDM)** (Bundled)

It is the library software, and which supplies command of hardware produced by our company in the form of standard Win32 API function(DLL). Using programming languages supporting Win32API functions, such as Visual Basic and Visual C++ etc., you can develop high-speed application software with feature of hardware produced by our company.

In addition, you can verify the operation of hardware using Diagnostic programs.

CONTEC provides download services (at <http://www.contec.com/apiusbp/>) to supply the updated drivers and differential files.

Further details may be found in the help within supplied CD-ROM or the homepage of our company.

< Operating Environment >

OS Windows Vista, XP, Server 2003, 2000, Me, 98

Adaptation language Visual Basic, Visual C++, Visual C#, Delphi, C++ Builder

Data acquisition VI library for LabVIEW VI-DAQ (Available for downloading (free of charge) from the CONTEC web site.)

This is a VI library to use in National Instruments LabVIEW.

VI-DAQ is created with a function form similar to that of LabVIEW's Data Acquisition VI, allowing you to use various devices without complicated settings.

See <http://www.contec.com/vidaq/> for details and download of VI-DAQ.

Cable & Connector (Option)

14pin Screw Terminal Connector Set(6 pieces) : CN6-Y14

Accessories (Option)

Bracket for USB I/O Terminal products : BRK-USB-Y

* Check the CONTEC's Web site for more information on these options.

Customer Support

CONTEC provides the following support services for you to use CONTEC products more efficiently and comfortably.

Web Site

Japanese <http://www.contec.co.jp/>
English <http://www.contec.com/>
Chinese <http://www.contec.com.cn/>

Latest product information

CONTEC provides up-to-date information on products.

CONTEC also provides product manuals and various technical documents in the PDF.

Free download

You can download updated driver software and differential files as well as sample programs available in several languages.

Note! For product information

Contact your retailer if you have any technical question about a CONTEC product or need its price, delivery time, or estimate information.

Limited Three-Years Warranty

CONTEC products are warranted by CONTEC CO., LTD. to be free from defects in material and workmanship for up to three years from the date of purchase by the original purchaser.

Repair will be free of charge only when this device is returned freight prepaid with a copy of the original invoice and a Return Merchandise Authorization to the distributor or the CONTEC group office, from which it was purchased.

This warranty is not applicable for scratches or normal wear, but only for the electronic circuitry and original products. The warranty is not applicable if the device has been tampered with or damaged through abuse, mistreatment, neglect, or unreasonable use, or if the original invoice is not included, in which case repairs will be considered beyond the warranty policy.

How to Obtain Service

For replacement or repair, return the device freight prepaid, with a copy of the original invoice. Please obtain a Return Merchandise Authorization Number (RMA) from the CONTEC group office where you purchased before returning any product.

* No product will be accepted by CONTEC group without the RMA number.

Liability



The obligation of the warrantor is solely to repair or replace the product. In no event will the warrantor be liable for any incidental or consequential damages due to such defect or consequences that arise from inexperienced usage, misuse, or malfunction of this device.

Safety Precautions

Understand the following definitions and precautions to use the product safely.

Safety Information

This document provides safety information using the following symbols to prevent accidents resulting in injury or death and the destruction of equipment and resources. Understand the meanings of these labels to operate the equipment safely.

 DANGER	DANGER indicates an imminently hazardous situation which, if not avoided, will result in death or serious injury.
 WARNING	WARNING indicates a potentially hazardous situation which, if not avoided, could result in death or serious injury.
 CAUTION	CAUTION indicates a potentially hazardous situation which, if not avoided, may result in minor or moderate injury or in property damage.

Handling Precautions

DANGER

Do not use the product where it is exposed to flammable or corrosive gas. Doing so may result in an explosion, fire, electric shock, or failure.

CAUTION

- Do not strike or bend the converter.
Otherwise, the converter may malfunction, overheat, cause a failure or breakage.
 - Do not touch the converter's pin parts (USB connector, GPIB connector) with your hands.
Otherwise, the converter may malfunction, overheat, or cause a failure.
If the pin parts are touched by someone's hands, clean the parts with industrial alcohol.
 - Do not touch the external connector (14 pin plug header) when the power is on.
Otherwise this may malfunction, overheat, cause a failure due to static electricity.
 - Make sure that your PC or expansion unit can supply ample power to all the products installed.
Insufficiently energized products could malfunction, overheat, or cause a failure.
 - The specifications of this product are subject to change without notice for enhancement and quality improvement.
Even when using the product continuously, be sure to read the manual and understand the contents.
 - Do not modify the product. CONTEC will bear no responsibility for any problems, etc., resulting from modifying this product.
 - Regardless of the foregoing statements, CONTEC is not liable for any damages whatsoever (including damages for loss of business profits) arising out of the use or inability to use this CONTEC product or the information contained herein.
-

FCC PART 15 Class A Notice

NOTE

This equipment has been tested and found to comply with the limits for a Class A digital device, pursuant to part 15 of the FCC Rules. These limits are designed to provide reasonable protection against harmful interference when the equipment is operated in commercial environment.

This equipment generates, uses, and can radiate radio frequency energy and, if not installed and used in accordance with the instruction manual, may cause harmful interference to radio communications. Operation of this equipment in a residential area is likely to cause harmful interference at his own expense.

WARNING TO USER

Change or modifications not expressly approved the manufacturer can void the user's authority to operate this equipment.

Environment

Use this product in the following environment. If used in an unauthorized environment, the converter may overheat, malfunction, or cause a failure.

Operating temperature

0 - 50°C

Humidity

10 - 90%RH (No condensation)

Corrosive gases

None

Floating dust particles

Not to be excessive

Inspection

Inspect the product periodically as follows to use it safely.

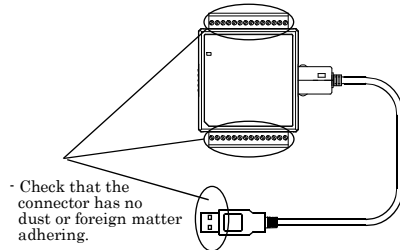

Storage

When storing this product, keep it in its original packing form.

- (1) Put the product in the storage bag.
- (2) Wrap it in the packing material, then put it in the box.
- (3) Store the package at room temperature at a place free from direct sunlight, moisture, shock, vibration, magnetism, and static electricity.

Disposal

When disposing of the product, follow the disposal procedures stipulated under the relevant laws and municipal ordinances.

2. Setup

This chapter explains how to set up the product.

What is Setup?

Setup means a series of steps to take before the product can be used.

Different steps are required for software and hardware.

Installing the driver

This section enables you to prepare the software and hardware by operating in accordance with each step in this chapter using the bundled CD-ROM. Taking the following steps sets up the software and hardware. You can use the diagnosis program later to check whether the software and hardware function normally.

Step 1 Setting the Hardware

Step 2 Installing the Software

Step 3 Installing the Hardware

Step 4 Checking Operations with the Diagnosis Program

Uninstall the driver and then set it up again if it cannot be set up properly.

Step 1 Setting the Hardware

This section describes how to set up the product and how to connect it to a PC.

Name of each parts

LED indicator

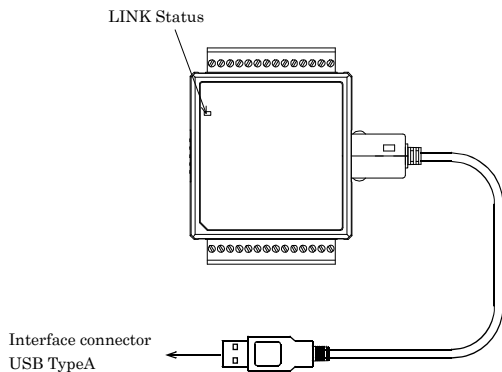

Figure 2.1. Name of each parts (Front side)

Table 2.1. List of Status LED Functions

Name	Function	Indicator color	LED indicator
LINK Status	USB communication status	GREEN	ON : Communication established
			OFF : Communication unestablished
	PC connection status		ON : PC communication established
			OFF : PC communication unestablished

Step 2 Initializing the Software

Install software.

The following description assumes the operating system as Windows XP. Although some user interfaces are different depending on the OS used, the basic procedure is the same.

Points

- If you are using Windows XP or Windows 2000, please log on as Administrator (authorized account) before proceeding to the following steps.

The following shows the basic flow for installing product.

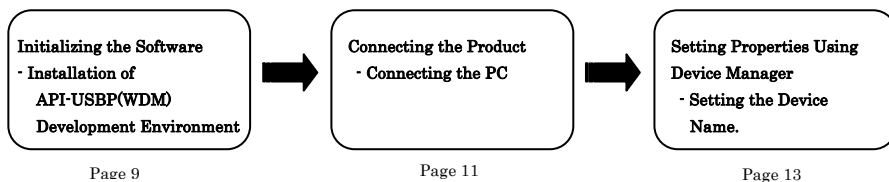
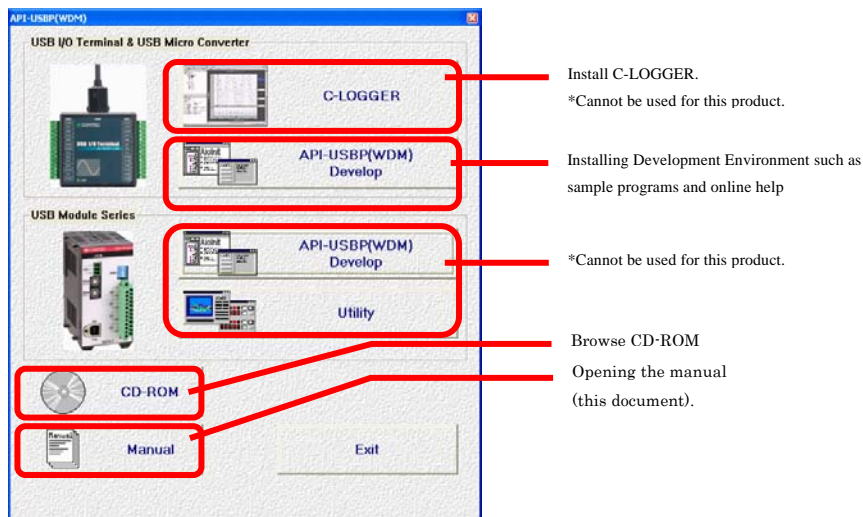

Illustration of Menu Screen



Points

- Please set up the supplied CD-ROM if it has not been set up. The menu starts automatically.
- If the menu do not start, launch X:AUTORUN.EXE(X:CD-ROM drive) from [Run...] in Start menu.
- The screen design may be different.

Installation of API-USBP(WDM) Development Environment

Installation of development environment is namely installing supplied online help and sample program in all language in order to use API function.

- (1) Clicking on “API-USBP(WDM) Develop”.

[Installing the development environment] dialog box displays.

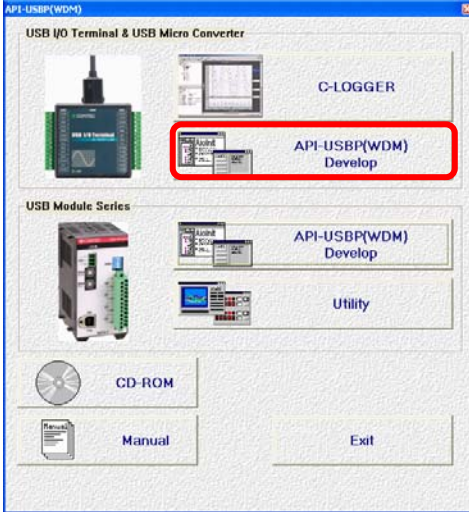

- (2) Selecting “Digital I/O”.



- (3) Clicking on “Continue” Button.

Please perform installation following the directions on the screen. And thus the installation is completed.

* The screen design may be different.

Step 3 Installing the Hardware

Under Windows, information about the converter needs to be detected by the OS. This is called hardware installation.

To use more than one of this product, make sure to install them one by one, setting each unit after completing the previous one.

Connecting the Product

- (1) Turn on the power to the PC before connecting the product.
- (2) When the PC has been up and running, plug the USB interface connector to a USB port in the PC. The converter can also be connected to the PC via a USB hub.

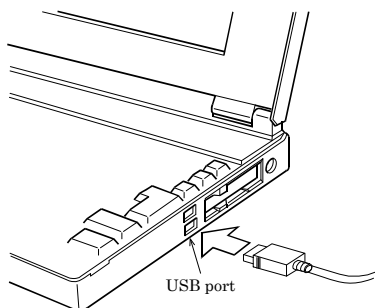

Figure 2.2. Connecting the PC

- (3) USB cable can be attached firmly to the main unit by using a USB cable attachment.

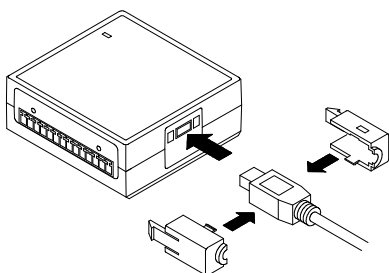

Figure 2.3. Attaching a USB Attachment

CAUTION

The USB cable attachment cannot be used excluding an attached cable.

Setting with the Add New Hardware Wizard

- (1) The “Found New Hardware Wizard” will be started.
 - * In Windows Vista, Because the driver's installation is completed by "Installing the Software", it is not necessary to operate it about the Hardware Wizard.
- (2) Select “Install from a list or specific location”, then click on the [Next] button.
 Detect setup information from supplied CD automatically for installing USB driver.



Point

Please specify the path for supplied CD as follows in the case of failure in detecting automatically.
 X:\¥IN¥¥WDM¥DIO (X: CD-ROM drive)

- (3) Click on [Finish] button to complete the installation of USB driver.

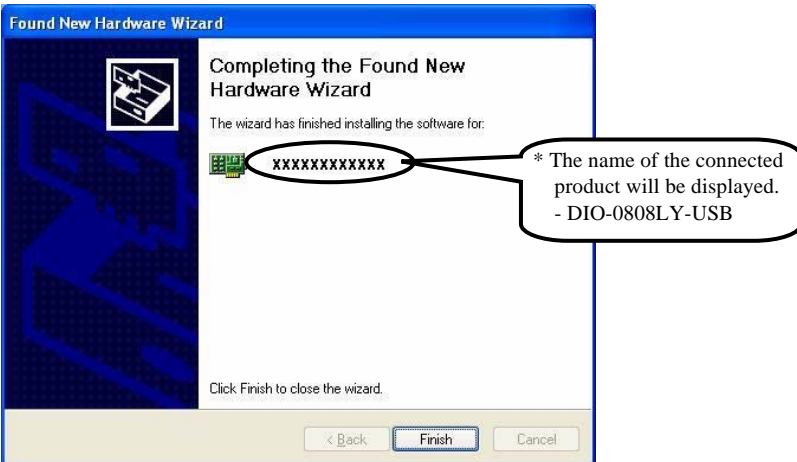

Setting Properties Using Device Manager

After connecting product with a PC and completing driver installation, open Device Manager and set properties.

(1) Starting Device Manager.

From [Start] menu, click on [Settings]-[Control Panel]-[System] and then click on [Device Manager] button in [Hardware] tab.

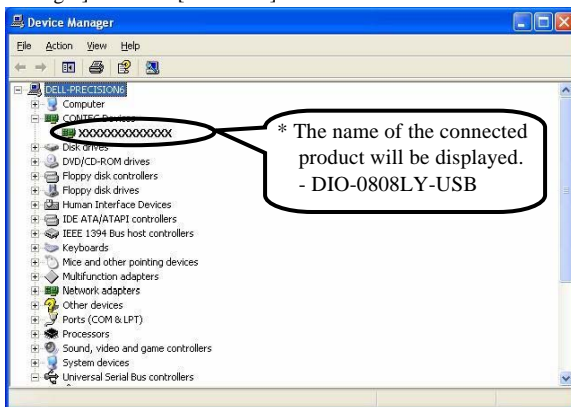

- In the case of Windows 98

Right-click on [My Computer] and select [Properties] to start device manager.

(2) Setting the Device Name.

Right-clicking on the product name and selecting [Properties] displays [Product Properties].

Open [Common Settings] tab and enter arbitrary name in the editing box for device name.

(Default name also can be used.)

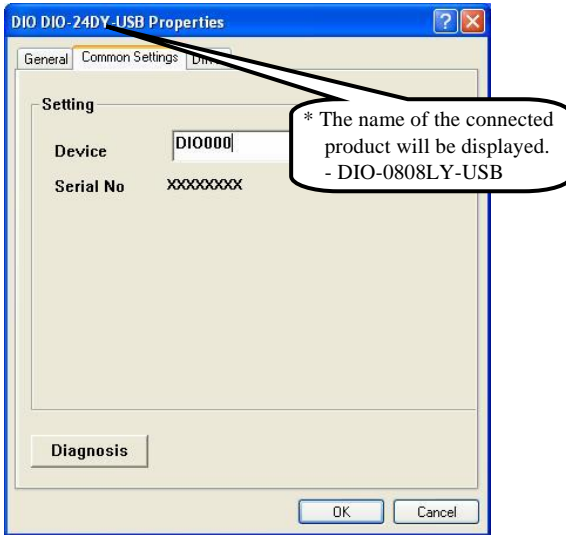

* The product-specific number will be displayed as the serial number.

⚠ CAUTION

USB driver can not be used without settings. Settings must be performed.

(3) Clicking on [OK] button.

Device name is set by clicking [OK] button.

Points

- When the application developed by users is running on another PC, please perform foregoing operation on the target computer. (No need to install software introduced on next page)
- Please use the device name specified in last step for initialization function when initialization is performed using API function. When running on other PC, it can run without changing the application for the same device name being specified.

Step 4 Checking Operations with the Diagnosis Program

Use the diagnosis program to check that the product and driver software work normally, thereby you can confirm that they have been set up correctly.

What is the Diagnosis Program?

The diagnosis program diagnoses the states of the product and driver software.

It can also be used as a simple checker when an external device is actually connected.

Using the “Diagnosis Report” feature reports the driver settings, the presence or absence of the product, I/O status, and interrupt status.

Using the Diagnosis Program

Starting the Diagnosis Program

Click [Diagnosis] on the Properties page to start the diagnosis program.

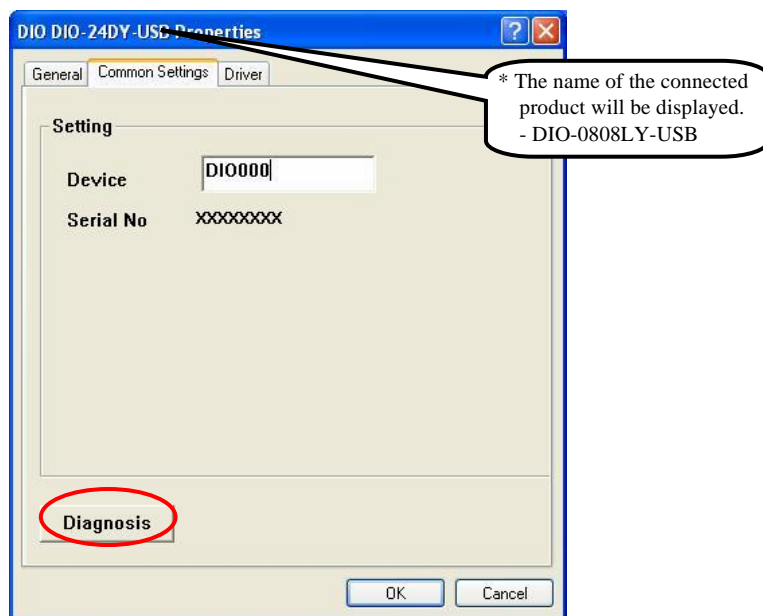

Checking Digital Inputs and Outputs

The main panel of the Diagnosis Program appears.

You can check the current operation states of the product in the following boxes:

“Input Port” : Displays input values bit by bit at fixed time intervals.

“Output Port” : Mouse operation allows the data to output or display.

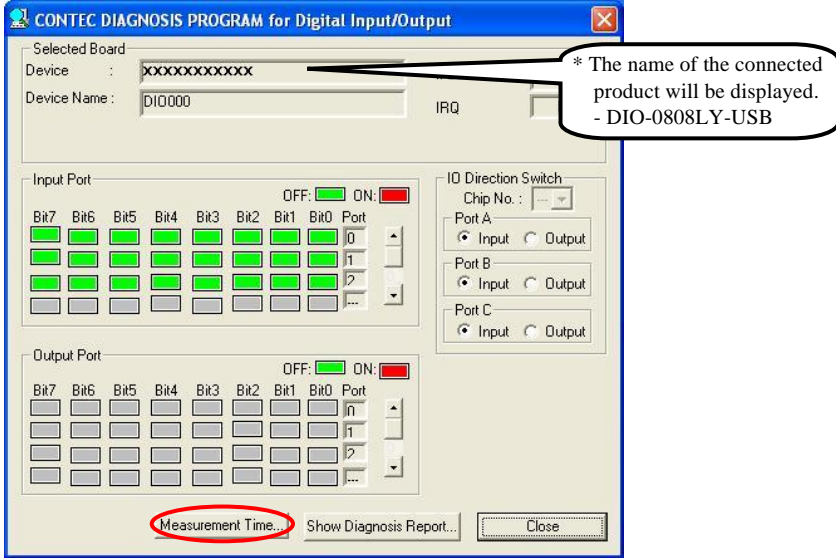

To use the function execution time measurement feature, click on the [Measurement Time] button.

Enter the I/O start port and the number of ports, then press the measurement button. The time for each execution of a function will be measured.

Diagnosis Report

- (1) Clicking on the [Show Diagnosis Report] button displays detailed data such as product settings and the diagnosis results while saving them in text format.

The Diagnosis Program performs “product presence/absence check”, “driver file test”, “product setting test”, and so on.

⚠ CAUTION

Before executing diagnosis report output, unplug the cable from the product.

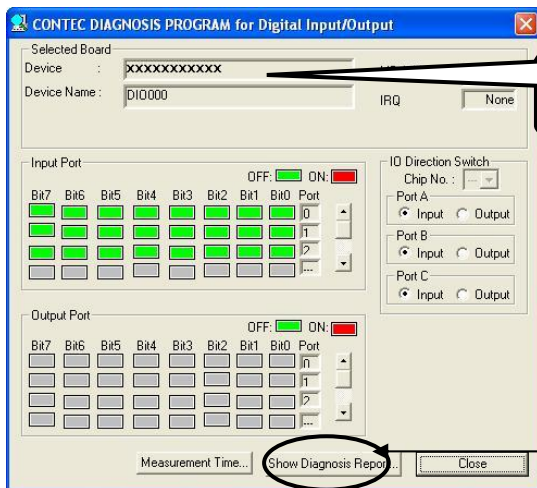

- (2) A diagnosis report is displayed as shown below.



3. External Connection

This chapter describes the interface connectors on the product.

Check the information available here when connecting an external device.

Using the On-terminal Connectors

Connecting a terminal to a Connector

To connect an external device to this terminal, plug the cable from the device into the interface connector (CN1, CN2) shown below.

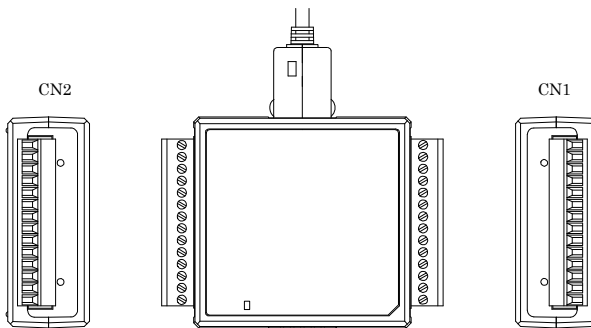

Figure 3.1. Interface Connectors and Mating Connectors

Connector Pin Assignment

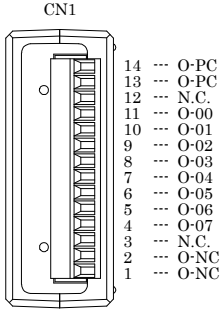

Figure 3.2. Pin Assignment of CN1

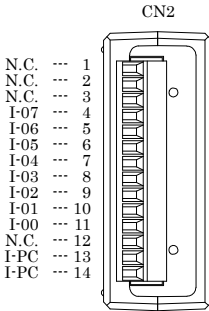

Figure 3.3. Pin Assignment of CN2

Table 3.1. Signal name of CN1 and CN2

I-00 - I-07	8 input signal pins. Connect output signals from the external device to these pins.
O-00 - O-07	8 output signal pins. Connect these pins to the input signal pins of the external device.
I-PC	Connect the positive side of the external power supply. These pins are common to 8 input signal pins.
O-PC	Connect the positive side of the external power supply. These pins are common to 8 output signal pins.
O-NC	Connect the negative side of the external power supply. These pins are common to 8 output signal pins.
N.C.	Connect the positive side of the external power supply. These pins are common to 8 input signal pins.

Relationships between Logical Ports/Bits and Connector Signal Pins

Pins

The following table lists the relationships between the connector signal pins and the logical port/bit numbers used for I/O functions.

Table 3.2. Logical Ports, Logical Bits, and Connector Signal Pins

	D7	D6	D5	D4	D3	D2	D1	D0
I/O Logical Ports0	I-07 [7]	I-06 [6]	I-05 [5]	I-04 [4]	I-03 [3]	I-02 [2]	I-01 [1]	I-00 [0]
I/O Logical Ports 1	O-07 [7]	O-06 [6]	O-05 [5]	O-04 [4]	O-03 [3]	O-02 [2]	O-01 [1]	O-00 [0]



CAUTION

The logical port and logical bit numbers are virtual port and bit numbers that enable programming independent of board I/O addresses or board types.

Cable connection

When connecting the product to an external device, you can use the supplied connector plug.

For wiring, strip off approximately 9 - 10mm of the covered part of a wire rod and then insert it to the opening. After the insertion, secure the wire rod with screws. Compatible wires are AWG 28 - 16.



CAUTION

Removing the connector plug by grasping the cable can break the wire.

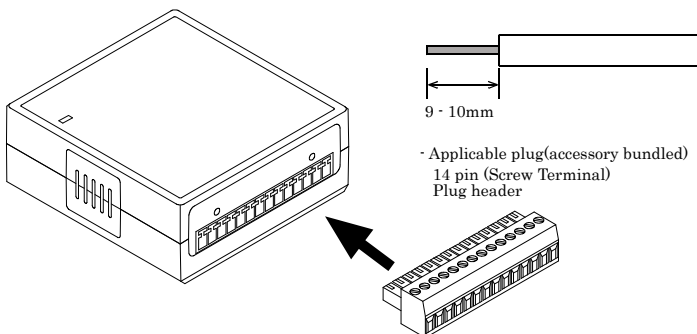
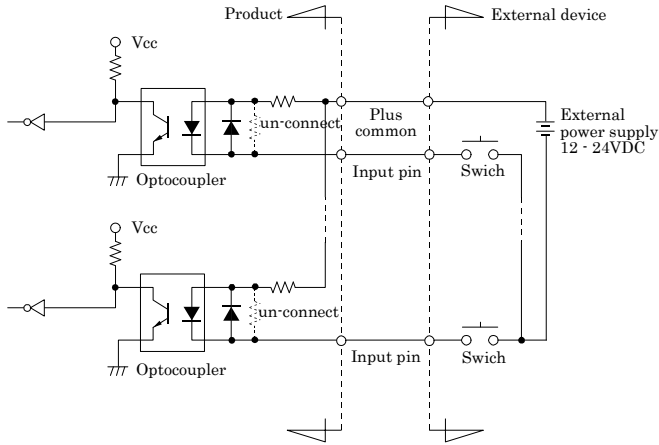

Figure 3.4. Connecting an Interface Connector and Connectors That Can Be Used

Connecting Input Signals

Input Circuit



* Input pin represent I-xx.

Figure 3.5. Input Circuit

The input circuit of this product is illustrated in Figure 3.5.

It is connected to devices such as switch and transistor output devices, which can be powered by an electric current. The ON/OFF state of a device that can be powered by an electric current is entered as a digital value.

The input channels are to be connected with current sinking output signals. Driving these opto-isolated circuits require an additional power supply isolated from the PC system. When a 12VDC external power is used, each input channel will consume about 2.6mA current; when a 24VDC external power is selected, each input channel will consume about 5.1mA current.

Connecting a Switch

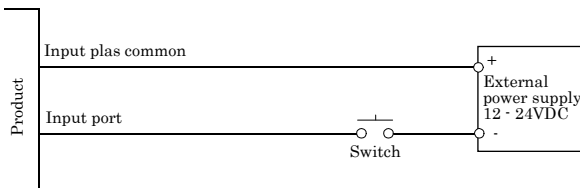

When the switch is ON, the corresponding bit contains 1.

When the switch is OFF, by contrast, the bit contains 0.

Figure 3.6. An Example to use Input

Output Circuit

Output Circuit

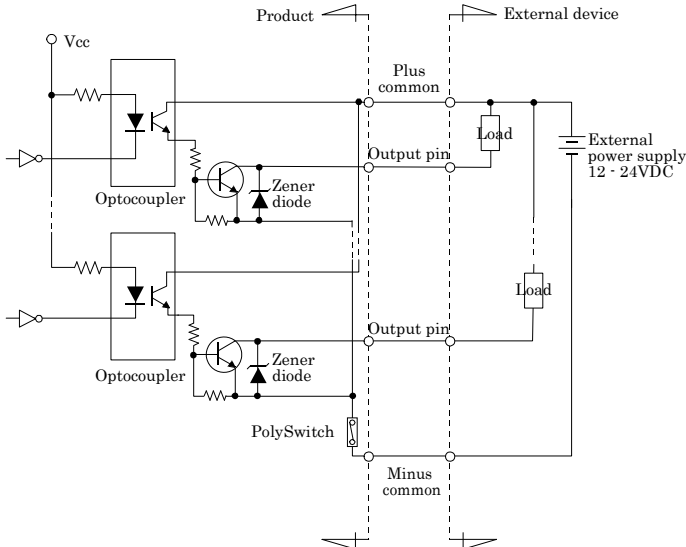

* Output pin: O:xx

Figure 3.7. Output Circuit

The output circuit of this product is illustrated in Figure 3.7. The signal output section is an opto-isolated, open-collector output (current sink type). Driving the output section requires an external power supply.

The rated output current per channel is 100 mA at maximum.

The output section can also be connected to a TTL level input as it uses a low-saturated transistor for output. The residual voltage (low-level voltage) between the collector and emitter with the output on is 0.5 V or less at an output current within 50 mA or at most 1.0 V at an output current within 100 mA.

A zener diode is connected to the output transistor for protection from surge voltages. A PolySwitch-based over-current protector is provided for every eight output transistors. When the over-current protector works, the output section of the product is temporarily disabled. If this is the case, turn off the power to the PC and the external power supply and wait for a few minutes, then turn them on back.



CAUTION

When the PC is turned on, all output are reset to OFF.

Example of Connection to LED

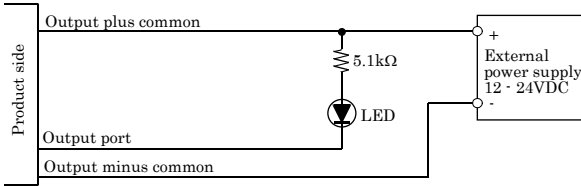

When "1" is output to a relevant bit, the corresponding LED comes on.
 When "0" is output to the bit, in contrast, the LED goes out.

Figure 3.8. An Example to use Output

Example of Connection to TTL Level Input

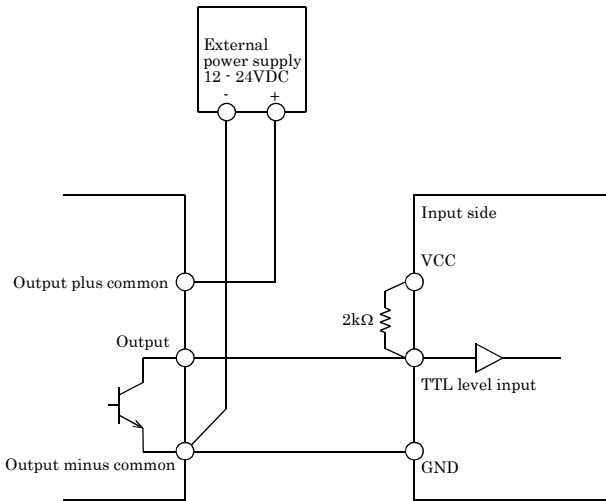

Figure 3.9. Connection Example of Output and TTL level Input Signal

Connecting the Sink Type Output and Sink Output Support Input

The following example shows a connection between a sink type output (output side) and a sink output support input (input side). Use this sample connection as a reference when connecting more than one of this product together.

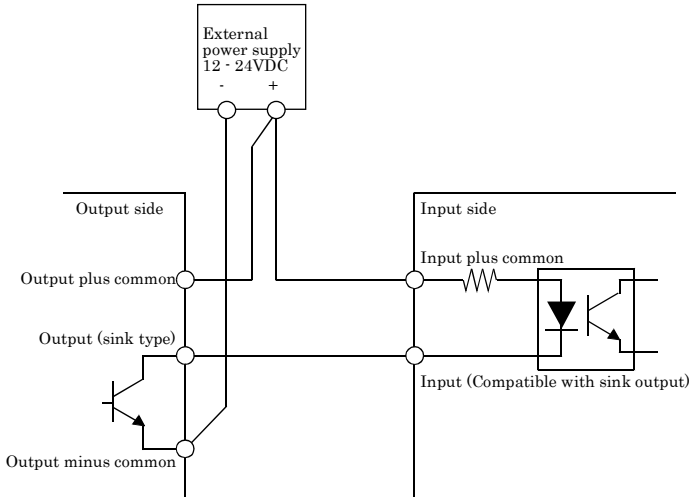

Figure 3.10. Example of Connecting the Sink Type Output and Sink Output Support Input

4. Application Development

Please reference to online help and sample program when developing applications.

Reference to Online Help

Click on [Programs]-[CONTEC API-USBP(WDM)]-[API-USBP(WDM) Help] from [Start] menu.

The information for application development, such as function reference is provided in [API-USBP(WDM) Help].

Detailed introduction to search method for help should be found from [How to navigate Help] in the help.

Printing Function Reference

Clicking on Print button from online help prints the page being displayed. It can be printed entirely as follows in the case of referencing to printing function.

As figure shown on the right, selecting  mark and clicking on Print button prints all the topics under the mark selected at a time.

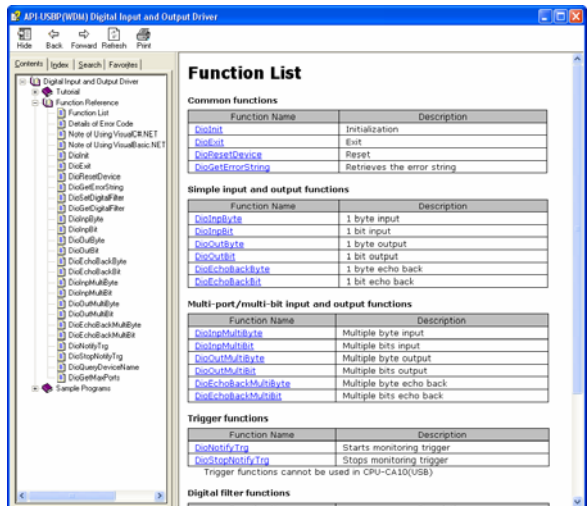

Sample Program

To run a sample program, click on [Programs] - [CONTEC API-USB(WDM)] - [Samples for Data I/O] - [Sample Name] from [Start] menu.

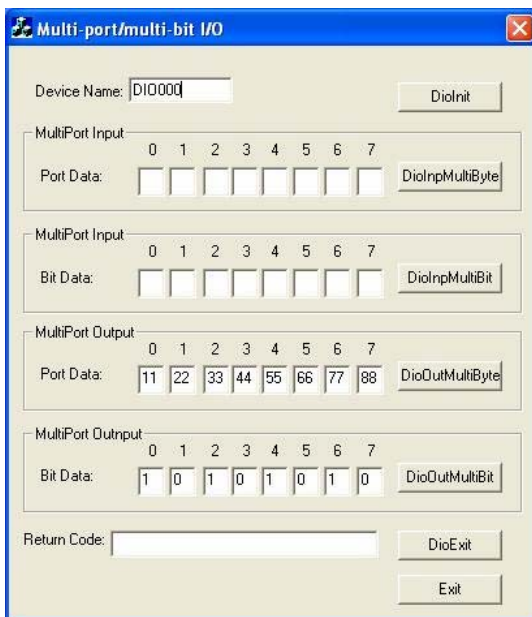

Distributing Developed Application

Please distribute the developed application with USB driver in supplied CD-ROM.

Returning to Initial State

This is the method of returning to initial state. It is suggested that you should return to initial state and perform installation again when the operation is losing stabilization.

- (1) Deleting Device form Device Manager.

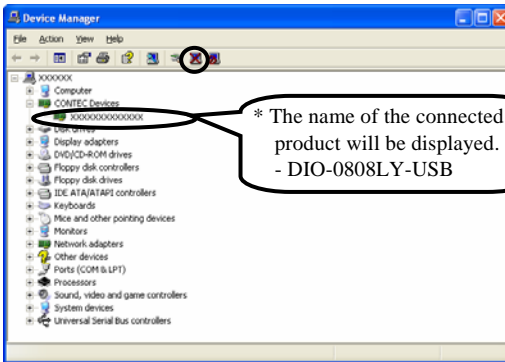

- (2) Drawing USB cable from a PC

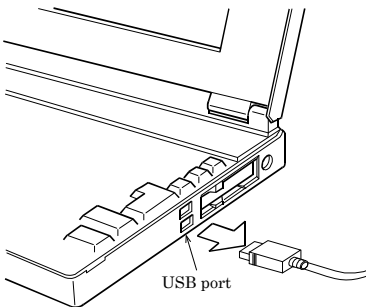

- (3) Uninstalling Driver
Select [CONTEC API-DIO(WDM) driver] from [My Computer]-[Control Panel]-[Add/Remove Programs].
- (4) Restarting

5. Functions

This section describes the functions of the product.

Data I/O Function

Data Input

When input data is “ON”, “1” is input to the relevant bit.

When the input data is “OFF”, in contrast, “0” is input to the relevant bit

Data Output

When “1” is output to the relevant bit, the corresponding transistor is set to “ON”.

When “0” is output to the relevant bit, in contrast, the corresponding transistor is set to “OFF”.



CAUTION

When the PC is turned on, all output are reset to 0 (OFF).

6. About Hardware

Hardware specification

Table 6.1. Specification (1/2)

Item		Specifications
Input section		
Number of input signal points		8 points (1 common)
Input format		Opto-isolated input (Compatible with current sink output) (Negative logic *1)
Input resistance		4.7 kΩ
Input ON current		2.0mA or more
Input OFF current		0.16mA or less
Response time		300μsec within *2
Output section		
Number of output signal points		8 points (1 common)
Output format		Opto-isolated open collector output (current sink type) (Negative logic*1)
Output rating	Output voltage	35VDC (Max.)
	Output current	100mA (per point) (Max.)
Residual voltage with output on		0.5V or less (Output current≤50mA), 1.0V or less (Output current≤100mA)
Surge protector		Zener diode RD47FM(NEC) or equivalent
Response time		300μsec within *2
USB		
Bus specification		USB Specification 2.0/1.1 standard
USB transfer rate		12Mbps (Full-speed), 480Mbps (High-speed) *3
Power supply		Bus power

*1 Data "0" and "1" correspond to the High and Low levels, respectively.

*2 The opto-coupler's response time comes.

*3 This depends on the host PC environment used (OS and USB host controller).

Table 6.1. Specification (2/2)

Item	Specifications
Common	
Connector	14 pin (screw-terminal) plug header
Number of terminals used at the same time	127 terminals (Max.) *4
Dielectric strength	1000Vrms
External circuit power supply	12 - 24VDC ($\pm 10\%$)
Current consumption (Max.)	5VDC 250mA
Operating conditions	0 - 50°C, 10 - 90%RH (No condensation)
Allowable distance of signal extension	Approx. 50m (depending on wiring environment)
External dimensions (mm)	64(W) x 62(D) x 24(H) (exclusive of protrusions)
Weight	70g (Not including the USB cable, attachment)
Attached cable	USB cable 1.8m
Compatible wires	AWG28 - 16

*4 As a USB hub is also counted as one device, you cannot just connect 127 USB terminals.

External dimensions

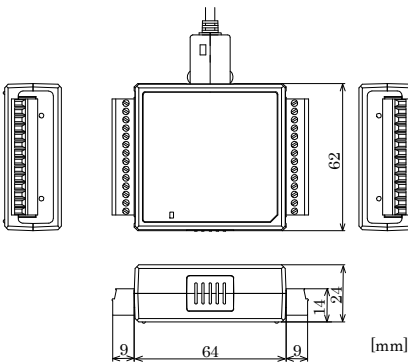
**Figure 6.1. External dimensions**

Block Diagram

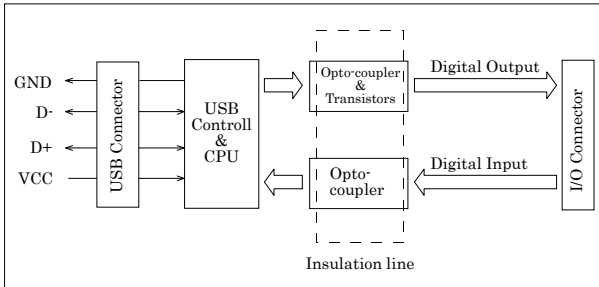

Figure 6.2. Block Diagram

DIO-0808LY-USB

User's Guide

CONTEC CO., LTD.

November 2007 Edition

3-9-31, Himesato, Nishiyodogawa-ku, Osaka 555-0025, Japan

Japanese <http://www.contec.co.jp/>

English <http://www.contec.com/>

Chinese <http://www.contec.com.cn/>

No part of this document may be copied or reproduced in any form by any means without prior written consent of CONTEC CO., LTD. [11122007]

[03102006]

Management No. A-51-075

[11122007_rev6]

Parts No. LYFZ694